

VAG SKR

Schrägsitz-Kipp-Rückschlagklappe

PN 10 / 16



Standardausführung / Standard version

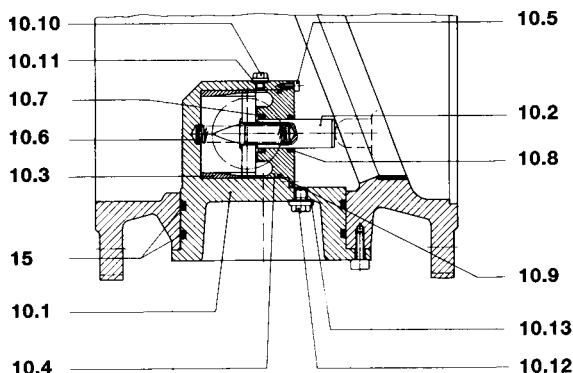
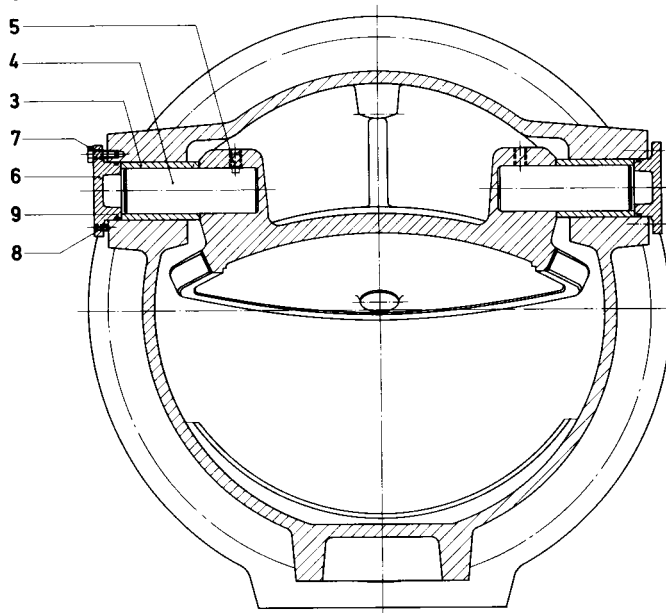
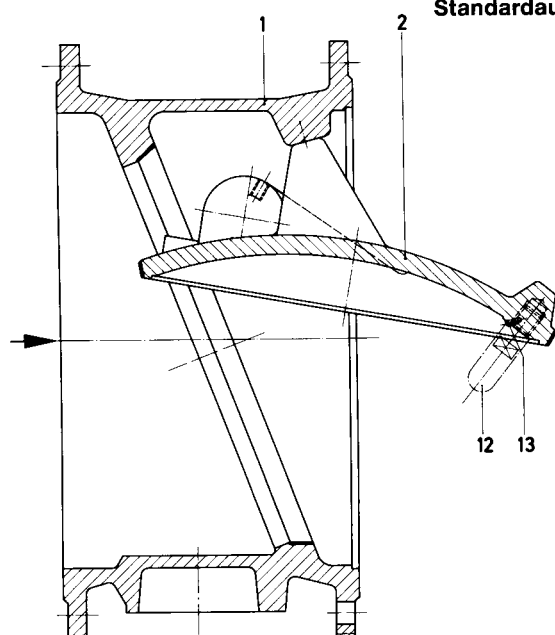

mit innenliegender Endlagendämpfung
with internal damper

mit Verschlussdeckel / with blind cover

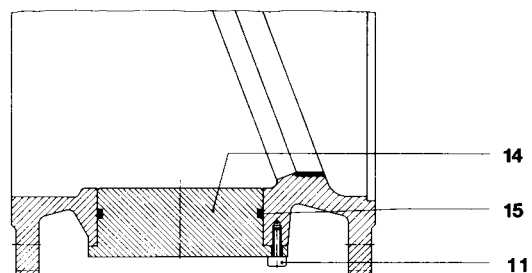

¹⁾ Empfohlene Ersatzteile / Recommended spare parts
²⁾ Verschleißteile / Parts subject to wear

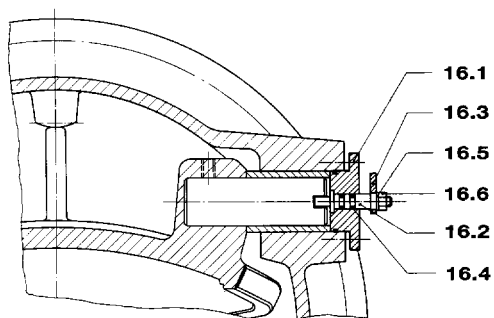

mit Klappenstellungsanzeige/
with position indicator

| Teil Part | Benennung / Description | | Material | ¹⁾ | ²⁾ |
|--------------|---------------------------|------------------------------------|---|---------------|---------------|
| 1 | Gehäuse | Body | GGG-40 (W.-Nr./Mat. no. 0.7040), DIN 1693 | | |
| 2 | Klappenscheibe | Disk | | | |
| 3 | Lagerbuchse | Bearing bush | G-CuSn10 (W.-Nr./Mat. no. 2.1050), DIN 1705 | • | |
| 4 | Weile | Shaft | X20Cr13 (W.-Nr./Mat. no. 1.4021), DIN 17440 | • | |
| 5 | Gewindestift DIN 915 | Threaded pin DIN 915 | A4-70 | • | |
| 6 | Lagerdeckel | Bearing cover | GGG-50 (W.-Nr./Mat. no. 0.7050), DIN 1693 | | |
| 7 | Sechskantschraube DIN 933 | Hexagon bolt DIN 933 | A4-70 | | |
| 8 | Gewindestift DIN 913 | Threaded pin DIN 913 | A4-70 | | |
| 9 | O-Ring | O-ring | EPDM | • | • |
| 10 | Dämpfer | Damper | GGG-50 / DN 200 u. 250 X 2 Cr Ni Mo N 22.5.3 | | |
| 11 | Zylinderschraube DIN 912 | Hex. socket head cap screw DIN 912 | A4-70 | | |
| 12 | Aufschlagbolzen | Impact bolt | X35CrMo17 (W.-Nr./Mat. no. 1.4122) | | |
| 13 | Gewindestift DIN 915 | Threaded pin DIN 915 | A4-70 | | |
| 14 | Verschlussdeckel | Lower blind cover | RSt37-2 (W.-Nr./Mat. no. 1.0038), DIN 17100 | | |
| 15 | O-Ring | O-ring | EPDM | • | • |
| 16.1 | Lagerdeckel | Bearing cover | X20Cr13 (W.-Nr./Mat. no. 1.4021), DIN 17440 | | |
| 16.2 | Zeigerwelle | Pointer shaft | X35CrMo17 (W.-Nr./Mat. no. 1.4122) | | |
| 16.3 | Zeiger | Pointer | CuZn39Pb2 (W.-Nr./Mat. no. 2.8380), DIN 17660 | | |
| 16.4 | O-ring | O-ring | EPDM | • | • |
| 16.5 | Scheibe DIN 125 | Washer DIN 125 | A4-70 | | |
| 16.6 | Sechskantmutter DIN 934 | Hexagon nut DIN 934 | A4-70 | | |

Ersatzteile

| Pos. | Benennung | Stck. | Sach-Nr. |
|---------------------------|--------------|-------|----------------|
| DN 200 / 250 PN 16 | | | |
| 3 | Lagerbuchse | 2 | 1-25-14061-250 |
| 4 | Welle | 2 | 1-23-32135-550 |
| 5 | Gewindestift | 2 | 1-75-33063-385 |
| 9 | O-Ring | 2 | 1-75-33277-165 |
| 15 | O-Ring | 2 | 1-75-33277-536 |
| 16.4 | O-Ring | 2 | 1-75-33277-274 |
| DN 300 PN 16 | | | |
| 3 | Lagerbuchse | 2 | 1-25-14062-250 |
| 4 | Welle | 2 | 1-23-32136-550 |
| 5 | Gewindestift | 2 | 1-75-33063-385 |
| 9 | O-Ring | 2 | 1-75-33277-564 |
| 15 | O-Ring | 2 | 1-75-33277-531 |
| 16.4 | O-Ring | 2 | 1-75-33277-274 |
| DN 350 PN 10 | | | |
| 3 | Lagerbuchse | 2 | 1-25-14350-250 |
| 4 | Welle | 2 | 1-23-32137-550 |
| 5 | Gewindestift | 2 | 1-75-33063-385 |
| 9 | O-Ring | 2 | 1-75-33277-561 |
| 15 | O-Ring | 2 | 1-75-33277-531 |
| 16.4 | O-Ring | 2 | 1-75-33277-274 |
| DN 400 PN 16 | | | |
| 3 | Lagerbuchse | 2 | 1-25-14092-250 |
| 4 | Welle | 2 | 1-23-32005-550 |
| 5 | Gewindestift | 2 | 1-75-33063-383 |
| 9 | O-Ring | 2 | 1-75-33277-495 |
| 15 | O-Ring | 2 | 1-75-33277-548 |
| 16.4 | O-Ring | 2 | 1-75-33277-274 |
| DN 450 PN 16 | | | |
| 3 | Lagerbuchse | 2 | 1-25-14333-250 |
| 4 | Welle | 2 | 1-23-32139-550 |
| 5 | Gewindestift | 2 | 1-75-33063-379 |
| 9 | O-Ring | 2 | 1-75-33277-217 |
| 15 | O-Ring | 2 | 1-75-33277-548 |
| 16.4 | O-Ring | 2 | 1-75-33277-274 |
| DN 500 PN 16 | | | |
| 3 | Lagerbuchse | 2 | 1-25-14333-250 |
| 4 | Welle | 2 | 1-23-32139-550 |
| 5 | Gewindestift | 2 | 1-75-33063-379 |
| 9 | O-Ring | 2 | 1-75-33277-217 |
| 15 | O-Ring | 2 | 1-75-33276-886 |
| 16.4 | O-Ring | 2 | 1-75-33277-274 |
| DN 600 PN 16 | | | |
| 3 | Lagerbuchse | 2 | 1-25-14063-250 |
| 4 | Welle | 2 | 1-23-24635-550 |
| 5 | Gewindestift | 2 | 1-75-33063-379 |
| 9 | O-Ring | 2 | 1-75-33277-176 |
| 15 | O-Ring | 2 | 1-75-33277-520 |
| 16.4 | O-Ring | 2 | 1-75-33277-274 |
| DN 700 PN 16 | | | |
| 3 | Lagerbuchse | 2 | 1-25-14481-250 |
| 4 | Welle | 2 | 1-23-24612-550 |
| 5 | Gewindestift | 2 | 1-75-33063-379 |
| 9 | O-Ring | 2 | 1-75-33277-178 |
| 15 | O-Ring | 2 | 1-75-33277-518 |
| 16.4 | O-Ring | 2 | 1-75-33277-274 |
| DN 800 PN 16 | | | |
| 3 | Lagerbuchse | 2 | 1-25-14481-250 |
| 4 | Welle | 2 | 1-23-24612-550 |
| 5 | Gewindestift | 2 | 1-75-33063-379 |
| 9 | O-Ring | 2 | 1-75-33277-180 |
| 15 | O-Ring | 2 | 1-75-33277-267 |
| 16.4 | O-Ring | 2 | 1-75-33277-274 |
| DN 900 PN 10 | | | |
| 3 | Lagerbuchse | 2 | 1-25-14508-250 |
| 4 | Welle | 2 | 1-23-24789-550 |
| 5 | Gewindestift | 2 | 1-75-33063-271 |
| 9 | O-Ring | 2 | 1-75-33277-180 |
| 15 | O-Ring | 2 | 1-75-33275-372 |
| 16.4 | O-Ring | 2 | 1-75-33277-274 |
| DN 1000 PN 10 | | | |
| 3 | Lagerbuchse | 2 | 1-25-14597-250 |
| 4 | Welle | 2 | 1-23-24714-550 |
| 5 | Gewindestift | 2 | 1-75-33063-271 |
| 9 | O-Ring | 2 | 1-75-33277-182 |
| 15 | O-Ring | 2 | 1-75-33277-552 |
| 16.4 | O-Ring | 2 | 1-75-33277-274 |



**VAG-
Armaturen
GmbH**

Carl-Reuther-Straße 1
D-68305 Mannheim
Postfach 31 05 48
D-68265 Mannheim
Telefon (0621) 749 - 0
Telefax (0621) 749 - 2153
Internet: www.vag-armaturen.com

© by VAG-Armaturen GmbH