

# Flood protection for the City of Bogen, Germany

VAG designs special valves to protect the City of Bogen against floods

VAG On-Site

6/08



The 'Gate to the Bavarian Forest' is how the Lower Bavarian city of Bogen describes itself. The medieval city is situated on the banks of the Danube between Straubing and Vilshofen. With the growing risk of floods, the proximity to the river is becoming an increasing danger to the 10,000 inhabitants and their possessions. That is why RMD Wasserstraßen GmbH and the water board of Deggendorf developed a flood protection plan for the City of Bogen as part of the in-depth investigations into the regulation of the section of the Danube between Straubing and Vilshofen. The plan is to prevent flood water from the hinterlands reaching the city by storing it in retention basins and using pumps to channel it through the Bogen stream into the Danube.

## Project overview

- Project:** Flood protection for the city of Bogen between Straubing and Vilshofen on the Danube
- Valves:** 30 EROX® Sluice Gates, DN 200 to DN 1200 with electric actuator, made to specifications with bevel gears and joints, able to withstand pressure ratios up to 1.2 bar  
1 ZETA® Knife Gate Valve, DN 250  
2 RETO-STOP Swing Check Valves, DN 250  
3 BETA® 300 Gate Valve, DN 250
- Project completion date:** 2007
- Builder:** The Free State of Bavaria and the German government, represented by the water board of Deggendorf
- Engineering:** Raimund Höllein Carolinenhütte GmbH
- Planning and construction supervising:** RMD Wasserstraßen GmbH, Munich



# Flood protection for the city of Bogen on the Danube

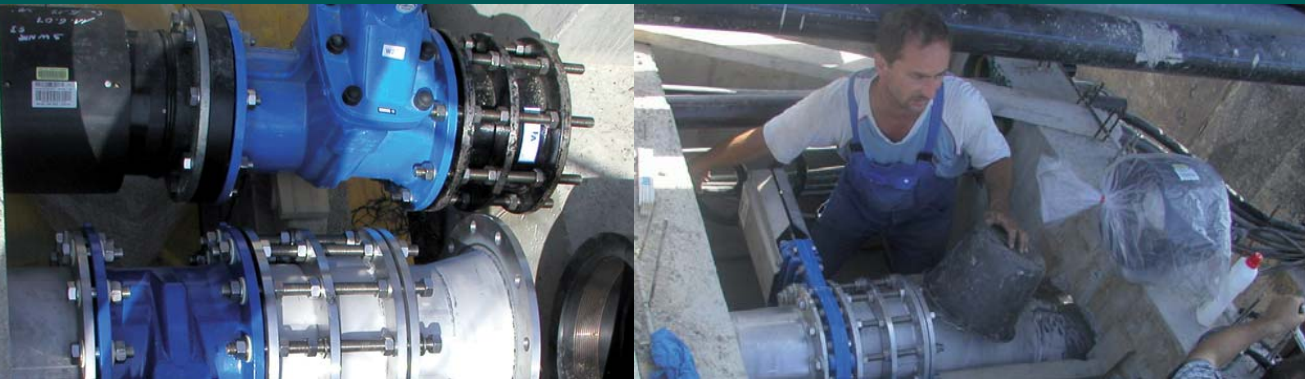

**VAG On-Site**

## On-site planning

The project was to be realised by remodelling the existing drainage station so it could work with two pumping stations. This meant that a storage basin, a pressure channel and a number of ducts had to be built from scratch.

The Free State of Bavaria and the German government commissioned the job to enhance the flood protection facilities: RMD Wasserstraßen GmbH was commissioned with the technical planning of this major and technically complex project, and Raimund Höllein Carolinenhütte GmbH was commissioned with the construction of the station.

## Planning and tender

The poor state of the existing buildings and the limited space for the required installations presented a major challenge. In addition, the valves had to be able to withstand enormous pressures in the event of a flood.

Following a public national tender, VAG-Armaturen GmbH was selected to supply the valves. VAG-Armaturen GmbH was, however, also selected because it's well known for its wide range of products and excellent quali-

ty and because the project required a large number of tailored solutions and custom products.

Because of the tight space in the drainage station, VAG's wastewater department planned to equip the valves'

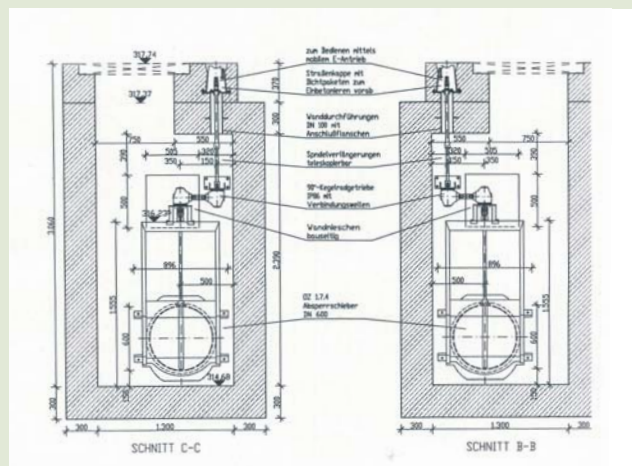

actuators with ball and socket joints and stem extensions. The plans were discussed and finalised in close cooperation with Höllein.

The valve production and the preparatory work were ready to begin.

The valves arrived on time in the spring of 2007. But numerous rainy spells had delayed the construction meaning that they actually ended up arriving ahead of schedule. Because

the valves were shrink-wrapped, they were well protected and could be stored outdoors at the site.

In the autumn of 2007, the following valves were installed:

30 EROX Sluice Gates with electric actuator in the versions 'Standard', 'Q' and 'R' in nominal sizes from DN 200 to DN 1200. All 30 Gate Valves were tailor made and specially reinforced for high pressures up to 1.2 bar (leak tightness was proved by tests carried out at the manufacturing plant).

- 1 ZETA Knife Gate Valve
- 2 RETO-STOP Swing Check Valves
- 3 BETA 300 Gate Valves

Wadim Heinrich, planning coordinator at Höllein, explains: 'VAG was an important partner in this project, which proved difficult to plan. Both companies had to be extremely flexible.'